

3 and 4 way valve

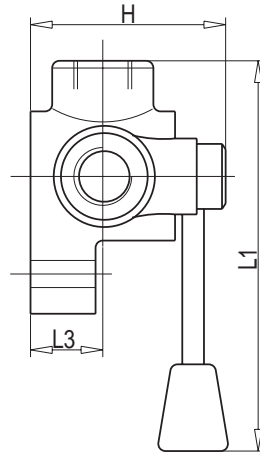

Hydraulisch schema
Schéma hydraulique

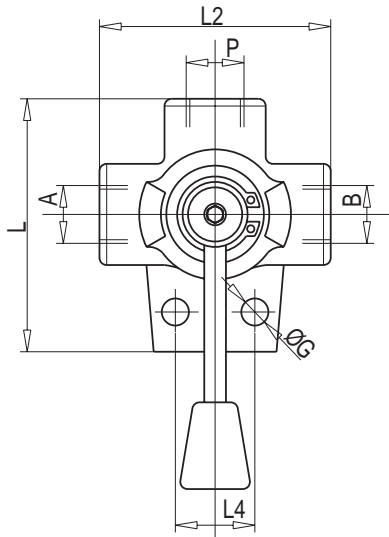
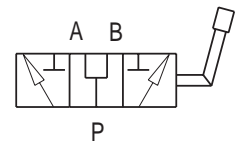

Bestelnr. Référence	TYPE	Max. Debiet Débit max.	A-B P	L	L1	L2	L3	L4	ÿ G	H
		Lt./min.	BSP	mm						
*	D.F 3/8	35	G3/8	77	140	70	24	26	8,5	68
*	D.F 1/2	60	G1/2	88	145	80	28	32	11	70
*	D.F 3/4	100	G3/4	102	150	95	30	32	11	80
*	D.F 1	180	G1	105	150	98	30	32	11	82

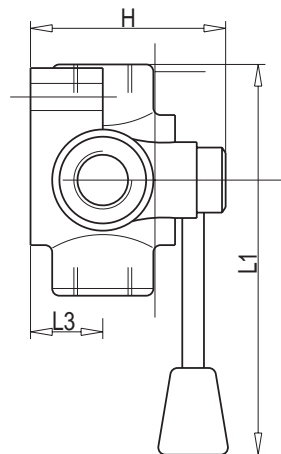
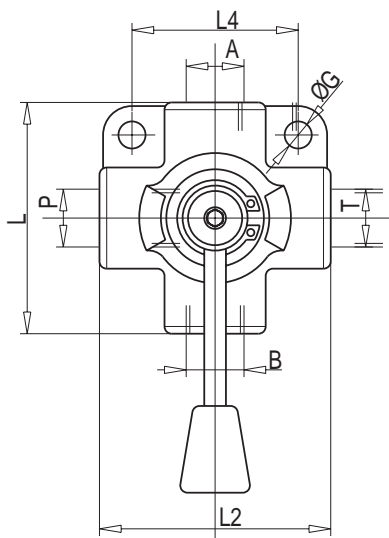

Hydraulisch schema
Schéma hydraulique

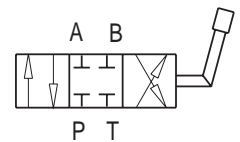

Bestelnr. Référence	TYPE	Max. Debiet Débit max.	A-B P-T	L	L1	L2	L3	L4	ÿ G	H
		Lt./min.	BSP	mm						
	I.F3/8	35	G 3/8	76	140	76	26	54	8,5	72
*	I.F1/2	60	G 1/2	88	145	88	30	65	8,5	82
*	I.F3/4	100	G3/4	95	180	95	32	74	8,5	90