

6 way valve

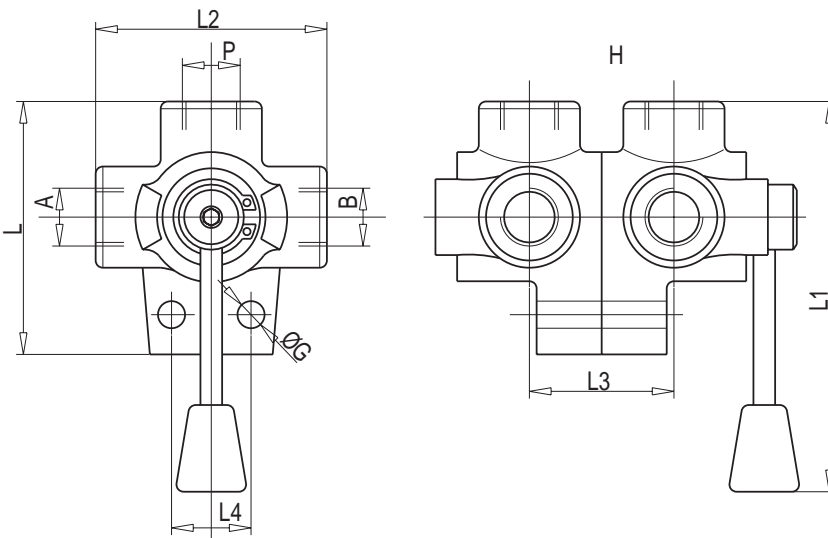

Hydraulisch schema
Schéma hydraulique

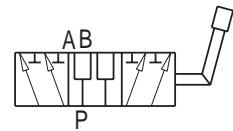

Bestelnr. Référence	TYPE	Max. debiet Débit max.	A-B P	L	L1	L2	L3	L4	ÿ G	H
		Lt./min.	BSP	mm						
	D.F.6 3/8	35	G3/8	77	140	70	45	26	8,5	118
	D.F.6 1/2	60	G1/2	88	145	80	50	32	11	125
	D.F.6 3/4	100	G3/4	102	150	95	60	32	11	155
	D.F.6 1	180	G1	105	150	98	60	32	11	155